

CBU-CESR

Ceiling Surface Mount Passive Infra Red (PIR) Occupancy Detector & Photocell

Input: 220-240 Vac 50Hz

CASAMBI



PLEASE READ THESE INSTRUCTIONS BEFORE INSTALLING THE PRODUCT

NOTE: CBU-CESR is only compatible to work with CASAMBI enable equipment

This surface mounted CBU-CESR can be mounted directly onto solid ceilings or onto a range of different mounting boxes. Configurable for any room occupancy style, via the free to download Casambi APP on Google Play or Apple APP Store.



INSTALLATION

To be installed by a competent person with reference to BS 7671 or equivalent local standards. If in doubt consult a qualified electrician.

- Plan where the CBU-CESR is to be located (see diagram 1). Switch off supply and check for hidden cables and pipes. Make a 73/75mm diameter hole through a standard ceiling board.
- The CBU-CESR should be connected as shown in diagram 2:
 - L - Live in. N - Neutral in.
- Knockout or drill the appropriate holes on the mounting plate for attaching the plate to the ceiling or back box (if applicable). Feed cables through the appropriate (side or rear) entry hole. Screw the back mounting plate to the ceiling or back box via the mounting holes. Wire the cables into the sensor head block terminal. Push the sensor head onto the mounting plate and align the side clips with the slots on the sensor heads.

OPERATION

To check the operation of the CBU-CESR:

- Turn on the supply then after 20 seconds if the sensor has recognised movement of a person within its zone of detection the integral red LED on CBU-CESR will stay illuminated for 4 seconds before the red LED turns off.
- Thereafter, every time movement is detected by CBU-CESR the integral red LED will stay illuminated for 4 seconds.

The control also features adjustable time out (time lag) control and daylight threshold control which are configured by the Casambi APP.

PRECAUTIONS

- Do not place the CBU-CESR near heat sources, fans or in ventilated ceiling voids.
- CBU-CESR can be wired in parallel (sharing the same Live and Neutral).
- Do not place close to, or positioned such that, any light source points directly into the CBU-CESR.
- Ensure wires and cables are securely held within the connection terminals.
- The CBU-CESR should be protected by a 5 or 6 Ampere mcb or fuse.
- Disconnect the CBU-CESR from the circuit before performing insulation testing of the wiring circuit.**

TECHNICAL DETAILS

INPUT	
Voltage:	220 - 240Vac
Frequency:	50Hz
Max. mains current:	0.05A
Standby current:	0.05A
RADIO TRANSCEIVER	
Operating frequencies:	2.4... 2,483 GHz
Max. output power:	+4 dBm
OPERATING CONDITIONS	
Note: The temperature difference between the detection target and the background must be at least 4 °C.	
Ambient temperature:	-20... +40 °C (Iout 0.05 A)
Max. case temperature:	+70 °C
Storage temperature:	-25... +75 °C
Max. relative humidity:	0... 80%, non cond.
CONNECTORS	
Terminal block	0.5mm ² - 2.5mm ²
Wire size:	solid or stranded
Wire strip length:	6-7mm
Tightening torque:	0,4 Nm/4 Kgf.cm
MECHANICAL DATA	
Dimensions:	45mm x 91mm x 91mm
Weight:	184g (unpacked)
Degree of protection:	IP20
Protection class:	Built-in Class 2
Material (casing)	Flame-retardant polycarbonate
Finish / Colour	Matt /White (RAL 9003)
Protection class:	Built-in Class 2
CONFORMITY AND STANDARDS	
EMC emission:	EN60669-2-1:2004 inc. A12:2010
EMC immunity:	EN60669-2-1:2004 inc. A12:2010
Safety:	EN60669-2-1:2004 inc. A12:2010
Environment:	Complies with WEEE and RoHS directives

5 YEAR WARRANTY

CBU-CESR comes with a 5 year warranty from the date of manufacture and is CE marked.

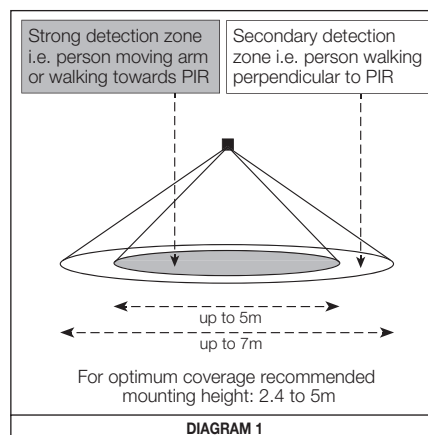

DIAGRAM 1

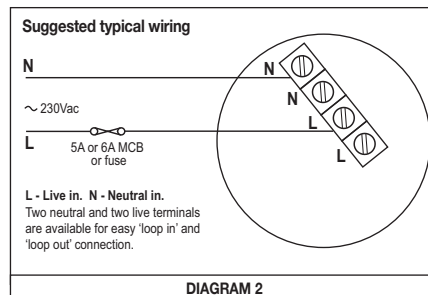

DIAGRAM 2

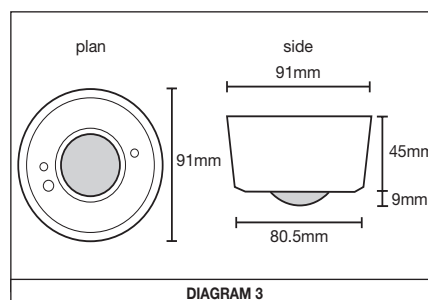

DIAGRAM 3